

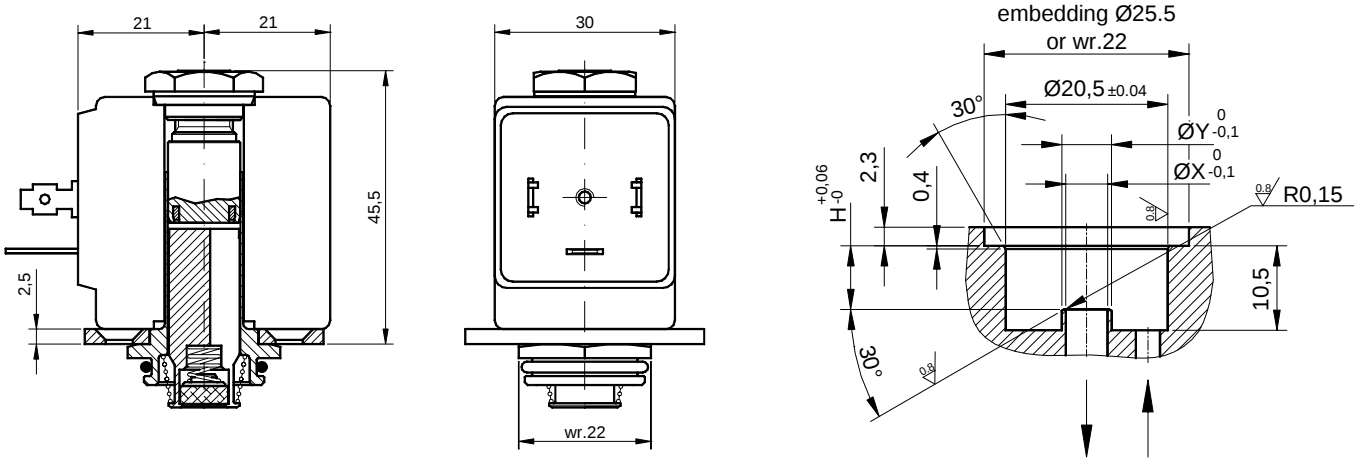

DESCRIPTION

Solenoid pilot 2 way normally closed. Tube Ø13 flange fixing.



CODE S.Steel Tube	Ø X mm	H mm	ØY mm	Differential pressure bar			Nominal power			Coil		Seal	Temp. range °C
				Min	Max		AC Inrush	VA Holding	DC Watt	Series	Width		
					AC	DC							
E670.....	1.5	7.7	4.2	0	30	26	20	15	10	2	30	NBR=B	-10 +90
	2	7.7	4.2	0	22	20	20	15	10	2	30		
	2.5	7.7	4.2	0	16	14	20	15	10	2	30	EPDM=E	<+140
	3.5	7.7	6.2	0	10	8	20	15	10	2	30		
	4.5	7.9	6.2	0	6.5	3.5	20	15	10	2	30		
5.2	7.9	6.2	0	4	1.8	20	15	10	2	30	FPM=V	-10 +130	

DESCRIPTION

Solenoid pilot 3 way normally closed. Tube Ø13 flange fixing.

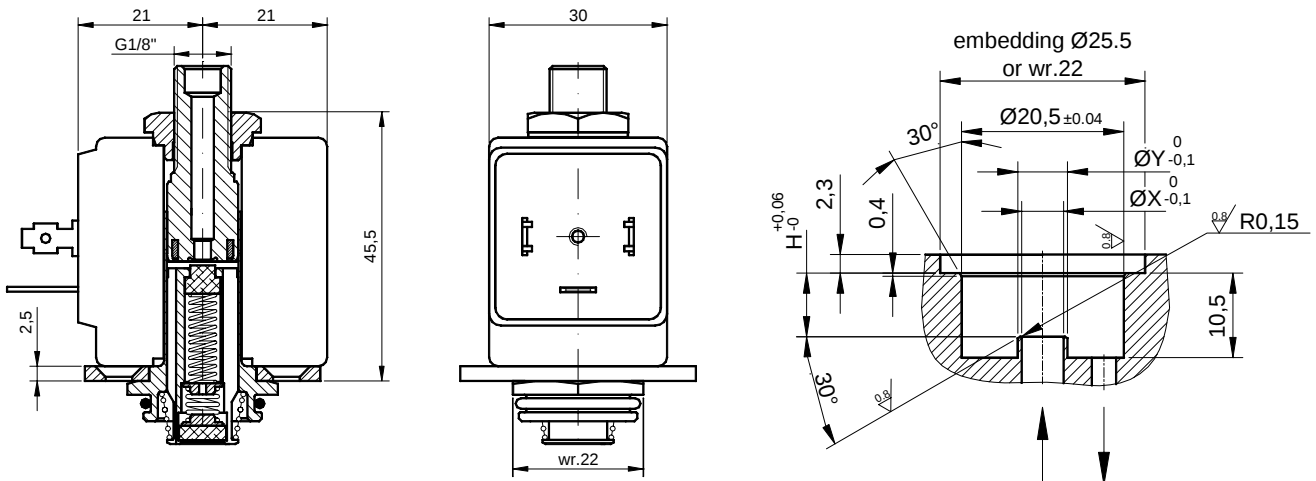

CODE S.Steel Tube	Ø X mm	H mm	Ø exh. mm	ØY mm	Differential pressure bar			Nominal power			Coil		Seal	Temp. range °C
					Min	Max		AC Inrush	VA Holding	DC Watt	Series	Width		
						AC	DC							
E680	1.5	7.7	2.4	4.2	0	20	20	20	15	10	2	30	NBR=B	-10 +90
	2	7.7	2.4	4.2	0	13	13	20	15	10	2	30	EPDM=E	<140
	2.5	7.7	2.4	4.2	0	10	10	20	15	10	2	30	FPM=V	-10 +130