

DESCRIPTION

Solenoid valve 2 way normally open direct acting poppet type.

CONSTRUCTION

Body	Brass
Armature tube	Brass
Plunger and core	Stainless steel
Springs	Stainless steel
Seal material	NBR
	FPM
	EPDM



2

FEATURES

Maximum allowable pressure 50 bar *
 Maximum fluid viscosity 25cSt (mm²/s)
 Ambient temperature : with class F coil -10°C +55°C
 with class H coil -10°C +80°C
 Universal mounting position

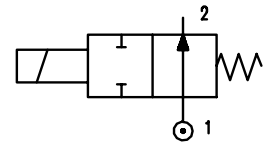

OPTIONS : Stainless steel armature tube
 Electroless nickel plating
 Explosion proof coil according to ATEX - EExmII Series 7

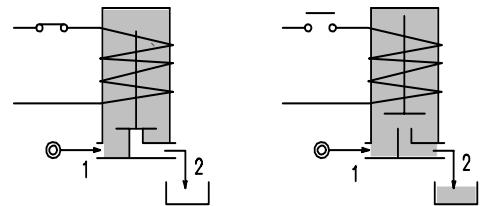

CODE ① ②	Flange	Orifice mm	KV m ³ /h	Differential pressure bar			Nominal power			Coil		Seal ①	Temp. Range °C
				Min	Max		AC Inrush	VA Holding	DC Watt	Series	Width		
					AC	DC							
E212X.....12///.....	Q 25	1.2	0.04	0	19	19	12	8	6.5	3	22	NBR=B EPDM=E FPM=V	-10 +90 <+140 -10 +130
E212X.....15///.....	Q 25	1.5	0.06	0	14	14	12	8	6.5	3	22		
E212X.....20///.....	Q 25	2	0.09	0	8	8	12	8	6.5	3	22		
E212X.....25///.....	Q 25	2.5	0.14	0	4.5	4.5	12	8	6.5	3	22		

- ① Seal
- ② Coil

Example: E212XB20///30B NBR seal
 Coil 24V 50/60Hz

Solenoid valve supplied without fixing screws

* REMARK: The maximum allowable pressure PS for steam is 2,5bar (gauge pressure)

COILS	Alternating Current ~50/60Hz Volt							Direct Current Volt			Electrical connection	Connectors
	12	24	48	110	220 230	240	380	12	24	48		
Series 3 Width 22 Code ②	30A	30B	30C	30D	30E	30F	30G	300	301	302	DIN 46244	PG9 code 10348000

DESCRIPTION
 Class F insulation
 Voltage tolerance
 AC +15% -10%
 DC ±10%
 Protection class
 IP65 with connector fitted
 IP00 without connector
 Continuous service ED100%

OPTIONS
 Class H insulation
 Cable attached
 Special coil voltages
 Special coil powers

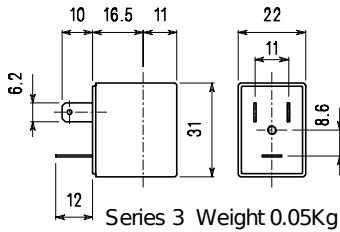

SPARE PARTS LIST

1. Coil fixing nut
2. Coil
3. Seal assembly
4. Armature tube

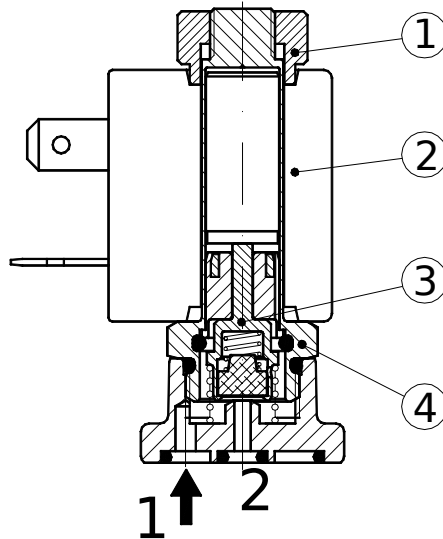

OVERALL DIMENSION

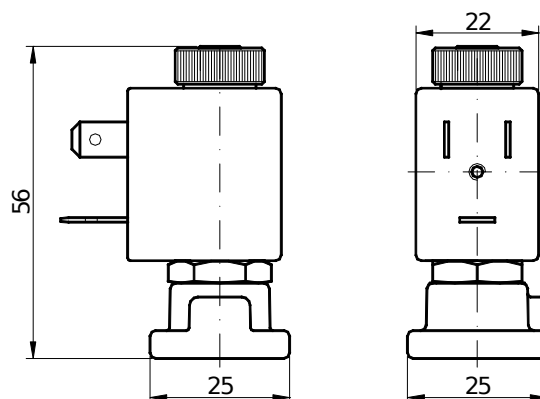
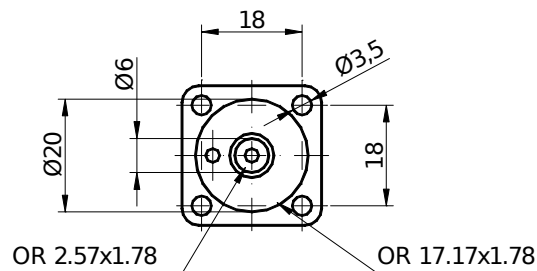

Weight = 0.12 Kg