

**DESCRIPTION**

Solenoid valve 2 way normally closed  
direct acting poppet type

**CONSTRUCTION**

Body	Brass
Armature tube	Stainless steel
Plunger and core	Stainless steel
Springs	Stainless steel
Seal material	NBR
	FPM
	EPDM
	PTFE



**2**

**FEATURES**

Maximum allowable pressure 80 bar \*  
Maximum fluid viscosity 25cSt (mm<sup>2</sup>/s)  
Ambient temperature : with class F coil -10°C +55°C  
with class H coil -10°C +80°C  
Universal mounting position

**OPTIONS :** Manual override  
Electroless nickel plating  
Stainless steel seat insert  
Version for use with oxygen

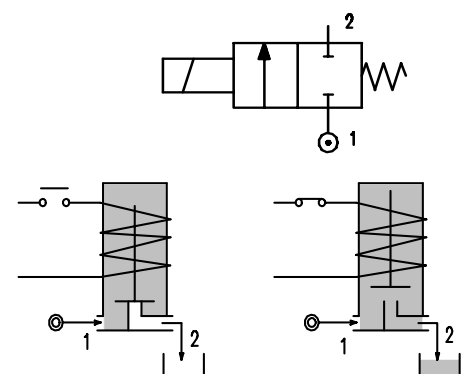

CODE ① ②	Connection G ISO 228	Orifice mm	KV m <sup>3</sup> /h	Differential pressure bar			Nominal power			Coil		Seal ①	Temp. Range °C
				Min	Max		AC Inrush	VA Holding	DC Watt	Series	Width		
					AC	DC							
E106A.....15///.....	1/8"	1.5	0.07	0	30	26	20	15	10	2	30	NBR=B	-10 +90
E106A.....20///.....	1/8"	2	0.1	0	22	20	20	15	10	2	30		
E106A.....25///.....	1/8"	2.5	0.15	0	16	14	20	15	10	2	30		
E106A.....35///.....	1/8"	3.5	0.32	0	10	8	20	15	10	2	30		
E106B.....15///.....	1/4"	1.5	0.07	0	30	26	20	15	10	2	30		
E106B.....20///.....	1/4"	2	0.1	0	22	20	20	15	10	2	30		
E106B.....25///.....	1/4"	2.5	0.15	0	16	14	20	15	10	2	30		
E106B.....35///.....	1/4"	3.5	0.32	0	10	8	20	15	10	2	30		
E106B.....45///.....	1/4"	4.5	0.41	0	6.5	3.5	20	15	10	2	30	EPDM=E	<+140
E106B.....52///.....	1/4"	5.2	0.47	0	4	1.8	20	15	10	2	30		
E106B.....64///.....	1/4"	6.4	0.64	0	3	1	20	15	10	2	30	FPM=V	-10 +130
E106A.....15///.....	1/8"	1.5	0.07	0	80	80	40	30	27	5	36		
E106A.....20///.....	1/8"	2	0.1	0	50	40	40	30	27	5	36		
E106A.....25///.....	1/8"	2.5	0.15	0	35	33	40	30	27	5	36		
E106A.....35///.....	1/8"	3.5	0.32	0	20	19	40	30	27	5	36		
E106B.....15///.....	1/4"	1.5	0.07	0	80	80	40	30	27	5	36		
E106B.....20///.....	1/4"	2	0.1	0	50	40	40	30	27	5	36		
E106B.....25///.....	1/4"	2.5	0.15	0	35	33	40	30	27	5	36		
E106B.....35///.....	1/4"	3.5	0.32	0	20	19	40	30	27	5	36	PTFE=W	-10 +160
E106B.....45///.....	1/4"	4.5	0.41	0	14	13	40	30	27	5	36		
E106B.....52///.....	1/4"	5.2	0.47	0	10	9	40	30	27	5	36		
E106B.....64///.....	1/4"	6.4	0.64	0	5	4.5	40	30	27	5	36		

① Seal Example: E106BB52///20E NBR seal  
 ② Coil Coil 220V 50/60Hz  
 ③ Maximum allowable leakage <0.2nL/h

\* REMARK: The maximum allowable pressure PS for steam is 6 bar (gauge pressure) with PTFE seals and 2,5bar with EPDM seals

COILS	Alternating Current ~50/60Hz Volt							Direct Current Volt			Electrical connection	Connectors
	12	24	48	110	220 230	240	380	12	24	48		
Series <b>2</b> Width 30 Code ②	20A	20B	20C	20D	20E	20F	20G	200	201	202	DIN 43650A	PG9 code 10349000
Series <b>5</b> Width 36 Code ②	52A	52B	52C	52D	52E	52F	52G	520	521	522	DIN 43650A	PG11 code 10349001

**DESCRIPTION**  
 Insulation class  
 Series 2=F Series 5=H  
 Voltage tolerance  
 AC +15% -10%  
 DC ± 10%  
 Protection class  
 IP65 with connector fitted  
 IP00 without connector  
 Continuous service ED100%

**OPTIONS**  
 Class H insulation (series 2)  
 Cable attached  
 Special coil voltages  
 Special coil powers

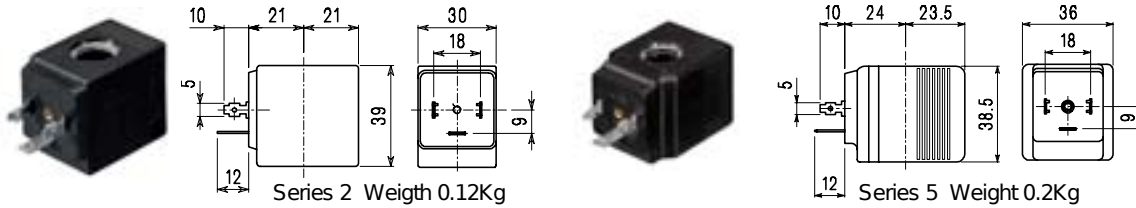

**SPARE PARTS LIST**

1. Coil fixing nut
2. Coil
3. Plunger
4. Armature tube with core

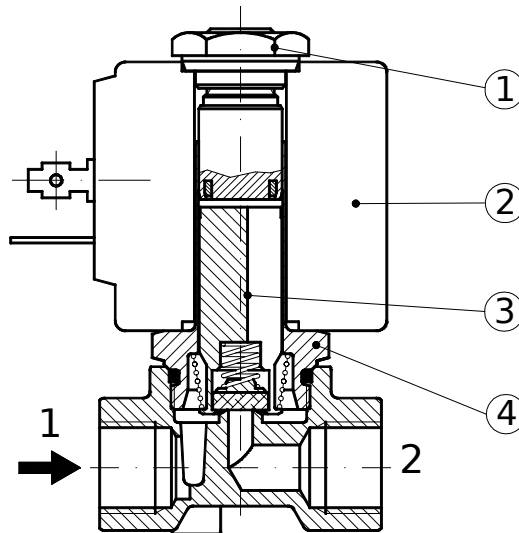

**MANUAL OVERRIDE**

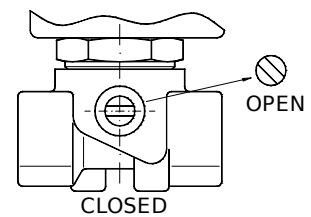

**OVERALL DIMENSION**

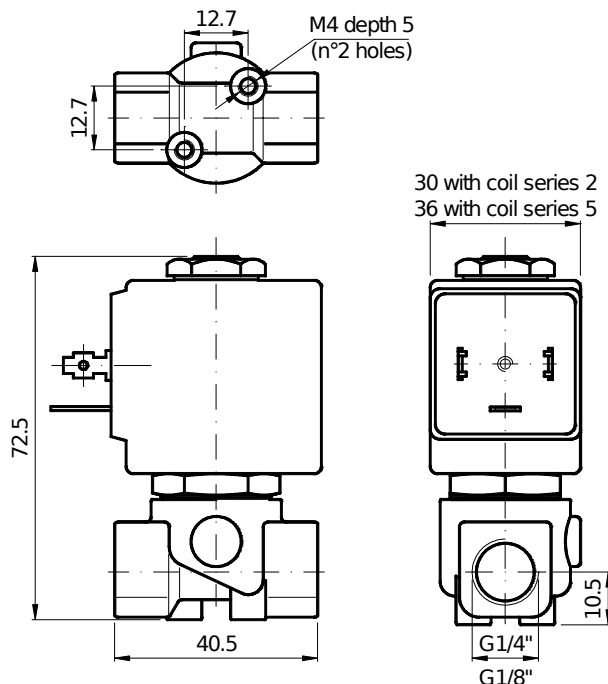

Weight with coil series 2 = 0.30 Kg  
 Weight with coil series 5 = 0.38 Kg

**DESCRIPTION**

Solenoid valve 2 way normally closed  
direct acting poppet type

**CONSTRUCTION**

Body	Brass
Armature tube	Stainless steel
Plunger and core	Stainless steel
Springs	Stainless steel
Seal material	NBR
	FPM
	EPDM
	PTFE



**2**

**FEATURES**

Maximum allowable pressure 80 bar \*  
 Maximum fluid viscosity 25cSt (mm<sup>2</sup>/s)  
 Ambient temperature : with class F coil -10°C +55°C  
 with class H coil -10°C +80°C  
 Universal mounting position

**OPTIONS :** Electroless nickel plating  
 For use with oxygen

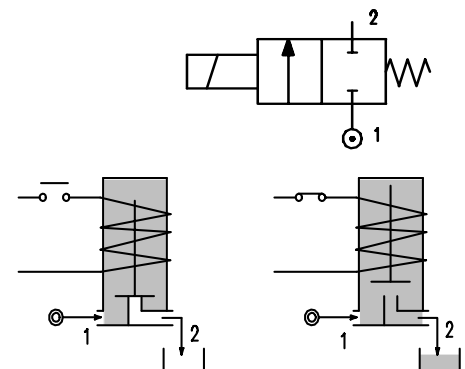

CODE ① ②	Connection G ISO 228	Orifice mm	KV m <sup>3</sup> /h	Differential pressure bar			Nominal power			Coil		Seal ①	Temp. range °C		
				Min	Max		AC Inrush	VA Holding	DC Watt	Series	Width				
					AC	DC									
E106C.....30///.....	3/8"	3	0.25	0	15	10	20	15	10	2	30	NBR=B	-10 +90		
E106C.....35///.....	3/8"	3.5	0.32	0	10	8	20	15	10	2	30				
E106C.....40///.....	3/8"	4	0.36	0	8	5	20	15	10	2	30				
E106C.....45///.....	3/8"	4.5	0.41	0	6.5	3.5	20	15	10	2	30				
E106D.....30///.....	1/2"	3	0.25	0	15	10	20	15	10	2	30	EPDM=E	<+140		
E106D.....35///.....	1/2"	3.5	0.32	0	10	8	20	15	10	2	30				
E106D.....40///.....	1/2"	4	0.36	0	8	5	20	15	10	2	30				
E106D.....45///.....	1/2"	4.5	0.41	0	6.5	3.5	20	15	10	2	30				
E106D.....52///.....	1/2"	5.2	0.47	0	4	1.8	20	15	10	2	30	FPM=V	-10 +130		
E106D.....64///.....	1/2"	6.4	0.64	0	3	1	20	15	10	2	30				
E106C.....30///.....	3/8"	3	0.25	0	25	24	40	30	27	5	36			PTFE=W	-10 +160
E106C.....35///.....	3/8"	3.5	0.32	0	20	19	40	30	27	5	36				
E106C.....40///.....	3/8"	4	0.36	0	16	15	40	30	27	5	36				
E106C.....45///.....	3/8"	4.5	0.41	0	14	13	40	30	27	5	36				
E106D.....30///.....	1/2"	3	0.25	0	25	24	40	30	27	5	36	③			
E106D.....35///.....	1/2"	3.5	0.32	0	20	19	40	30	27	5	36				
E106D.....40///.....	1/2"	4	0.36	0	16	15	40	30	27	5	36				
E106D.....45///.....	1/2"	4.5	0.41	0	14	13	40	30	27	5	36				
E106D.....52///.....	1/2"	5.2	0.47	0	10	9	40	30	27	5	36				
E106D.....64///.....	1/2"	6.4	0.64	0	5	4.5	40	30	27	5	36				

- ① Seal Example: E106CE35///521 EPDM seal
- ② Coil Coil 24V DC
- ③ Maximum allowable leakage <0.2 nL/h

\* REMARK: The maximum allowable pressure PS for steam is 6 bar (gauge pressure) with PTFE seals and 2,5bar with EPDM seals

COILS	Alternating Current ~50/60Hz Volt							Direct Current Volt			Electrical connection	Connectors
	12	24	48	110	220 230	240	380	12	24	48		
Series <b>2</b> Width 30 Code ②	20A	20B	20C	20D	20E	20F	20G	200	201	202	DIN 43650A	PG9 code 10349000
Series <b>5</b> Width 36 Code ②	52A	52B	52C	52D	52E	52F	52G	521	521	522	DIN 43650A	PG11 code 10349001

**DESCRIPTION**  
 Insulation class  
 Series 2=F Series 5=H  
 Voltage tolerance  
 AC +15% -10%  
 DC ±10%  
 Protection class  
 IP65 with connector fitted  
 IP00 without connector  
 Continuous service ED100%

**OPTIONS**  
 Class H insulation (series 2)  
 Cable attached  
 Special coil voltages  
 Special coil powers

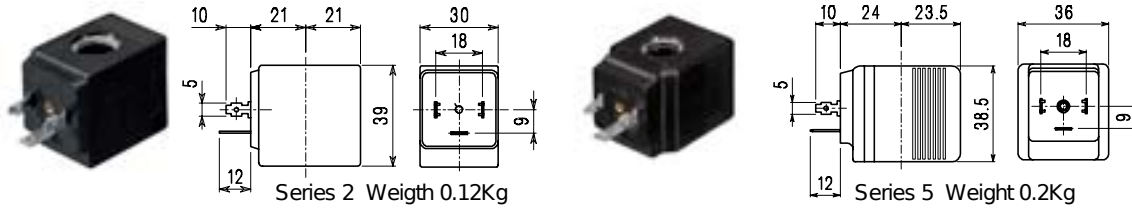

**SPARE PARTS LIST**

1. Coil fixing nut
2. Coil
3. Plunger
4. Armature tube with core

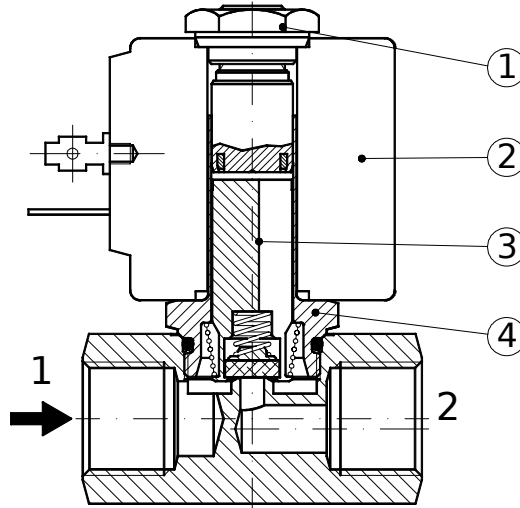

**OVERALL DIMENSION**

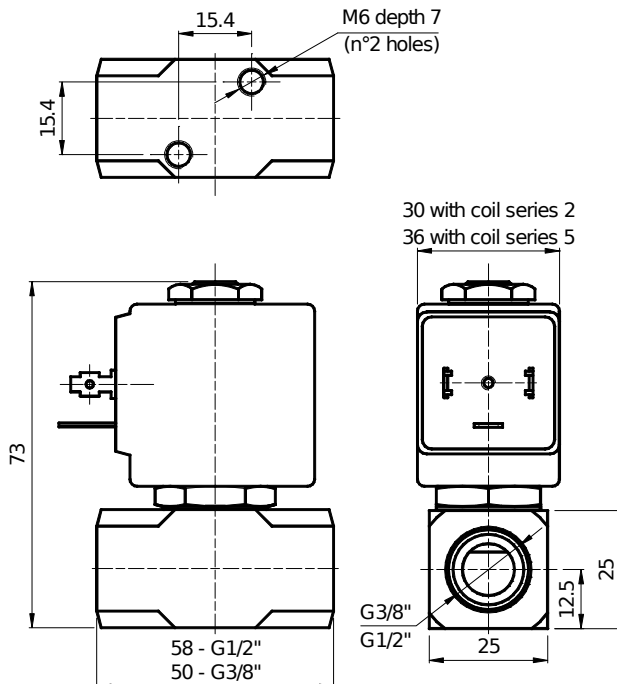

Weight with coil series 2 = 0.36 Kg  
 Weight with coil series 5 = 0.44 Kg