

DESCRIPTION

Solenoid valve 2 way normally closed
direct acting poppet type

CONSTRUCTION

Body	Brass
Armature tube	Brass
Plunger and core	Stainless steel
Springs	Stainless steel
Seal material	FPM



2

FEATURES

Maximum allowable pressure 50 bar *
 Maximum fluid viscosity 25cSt (mm²/s)
 Ambient temperature : with class F coil -10°C +55°C
 with class H coil -10°C +80°C
 Universal mounting position

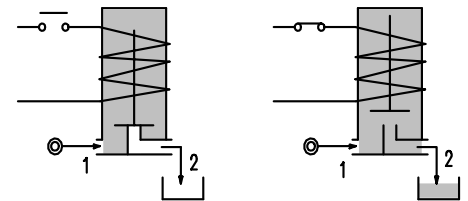
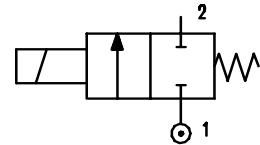

CODE ②	Connection G ISO 228	Orifice mm	KV m ³ /h	Differential pressure bar			Nominal power			Coil		Seal	Temp. range °C
				Min	Max		AC Inrush	VA Holding	DC Watt	Series	Width		
					AC	DC							
W105AV15///.....	1/8"	1.5	0.06	0	14	3	12	8	6.5	3	22	FPM=V	-10 +130

② Coil

* REMARK: The maximum allowable pressure PS for steam is 2,5bar (gauge pressure)

COILS	Alternating Current ~50/60Hz Volt							Direct Current Volt			Electrical connection	Connectors
	12	24	48	110	220 230	240	380	12	24	48		
Series 3 Width 22 Code ②	30A	30B	30C	30D	30E	30F	30G	300	301	302	DIN 46244	PG9 code 10348000

DESCRIPTION
 Class F insulation
 Voltage tolerance
 AC +15% -10%
 DC ±10%
 Protection class
 IP65 with connector mounted
 IP00 without connector
 Continuous service ED100%

OPTIONS
 Class H insulation
 Cable attached
 Special coil voltage
 Special coil powers

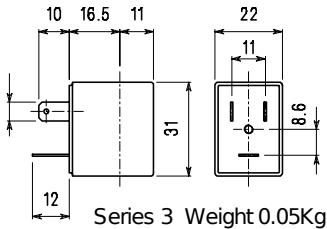

SPARE PARTS LIST

1. Coil fixing nut
2. Coil
3. Valve

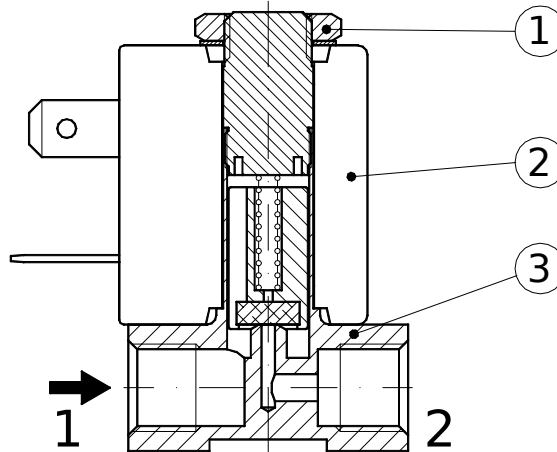

OVERALL DIMENSION

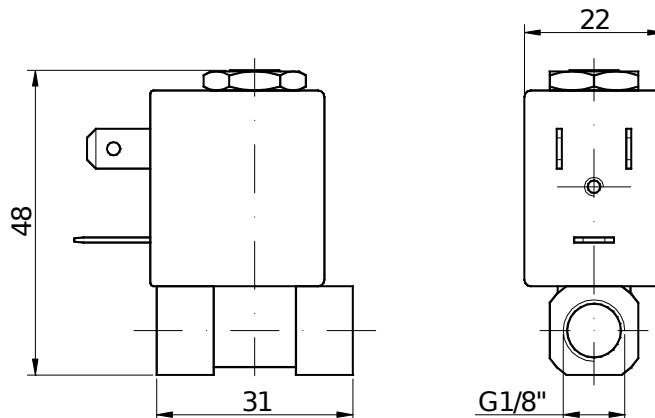

Weight = 0.09 Kg