

DESCRIPTION

Solenoid valve 2 way normally closed direct acting poppet type.
 With explosion proof coil certified:
 CESI 03 ATEX 344 ExII2G/D Eex "d" IIC T6

VALVE CONSTRUCTION

Body Brass
 Seal material FPM

EXPLOSION PROOF CONSTRUCTION

Housing Red colour alloy
 Electrical connection 1/2" NPT



2

FEATURES

Maximum allowable pressure 80 bar
 Maximum fluid viscosity 25cSt (mm²/s)
 Ambient temperature : -10°C +40°C
 Mounting position with vertical coil above

OPTIONS : Manual override
 Electroless nickel plating
 Stainless steel seat

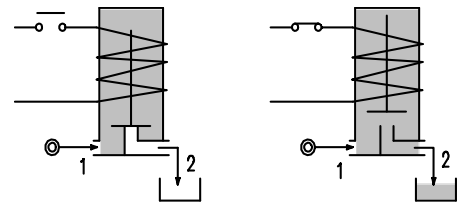
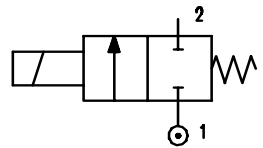

NOTE: The solenoid valve is suitable for contact with **NOT** potential explosive medias only.

CODE ^②	Connection G ISO 228	Orifice mm	KV m ³ /h	Differential pressure bar			Nominal power		Coil Series	Seal	Temperature range °C
				Min	Max		AC Holding	DC Watt			
					AC	DC					
A106AV15///.....	1/8"	1.5	0.07	0	30	26	12 VA	8 W	A6	FPM=V	-10 +130
A106AV20///.....	1/8"	2	0.1	0	22	20					
A106AV25///.....	1/8"	2.5	0.15	0	16	14					
A106AV35///.....	1/8"	3.5	0.32	0	10	8					
A106BV15///.....	1/4"	1.5	0.07	0	30	26					
A106BV20///.....	1/4"	2	0.1	0	22	20					
A106BV25///.....	1/4"	2.5	0.15	0	16	14					
A106BV35///.....	1/4"	3.5	0.32	0	10	8					
A106BV45///.....	1/4"	4.5	0.41	0	6.5	3.5					
A106BV52///.....	1/4"	5.2	0.47	0	4	1.8					
A106BV64///.....	1/4"	6.4	0.64	0	3	1					

② Coil

COILS	Alternating Current ~50/60Hz Volt				Direct Current Volt			Electrical connection
	24	48	110	220 230	12	24	48	
Series A6 Code ②	A6B	A6C	A6D	A6E	A60	A61	A62	1/2" NPT

DESCRIPTION
Voltage tolerance
AC +15% -10%
DC ±10%
Protection class IP66

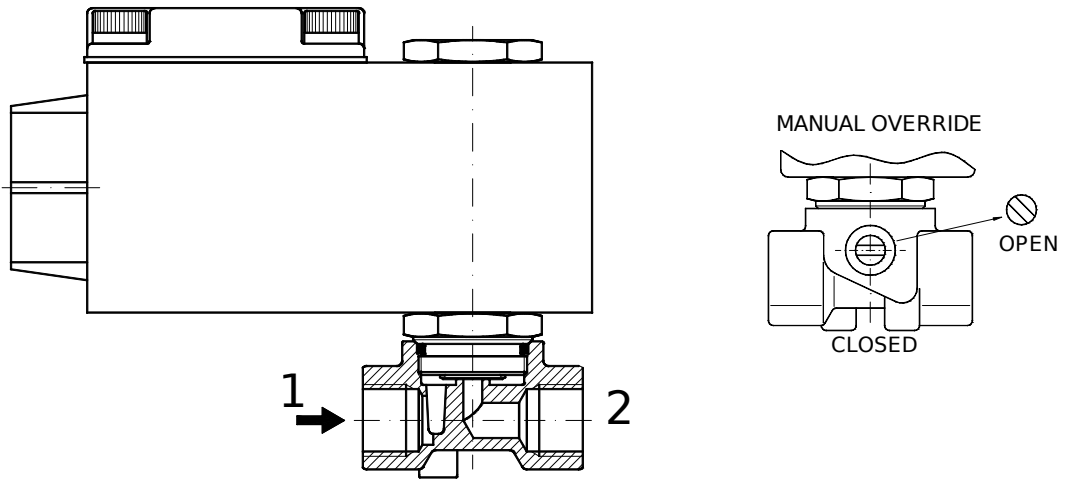

OVERALL DIMENSION

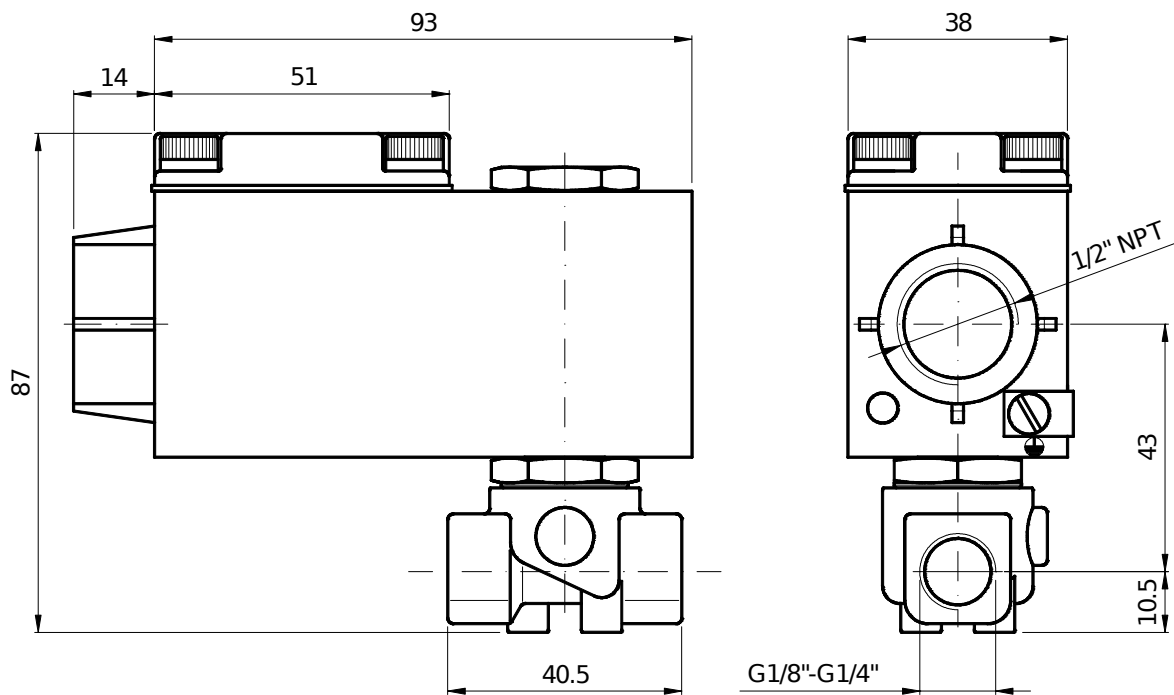

Weight = 0.60 Kg

DESCRIPTION

Solenoid valve 2 way normally closed direct acting poppet type.
 With explosion proof coil certified:
 CESI 03 ATEX 344 ExII2G/D Eex "d" IIC T6

VALVE CONSTRUCTION

Body Brass
 Seal material FPM

EXPLOSION PROOF CONSTRUCTION

Housing Red colour alloy
 Electrical connection 1/2" NPT



2

FEATURES

Maximum allowable pressure 80 bar
 Maximum fluid viscosity 25cSt (mm²/s)
 Ambient temperature : -10°C +40°C
 Mounting position with vertical coil above

OPTIONS : Electroless nickel plating
 Stainless steel seat

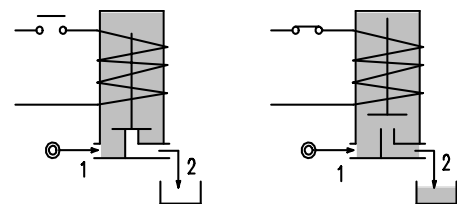
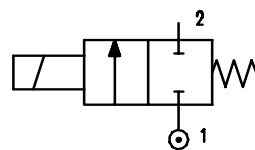

NOTE: The solenoid valve is suitable for contact with **NOT** potential explosive medias only.

CODE ②	Connection G ISO 228	Orifice mm	KV m ³ /h	Differential pressure bar			Nominal power		Coil Series	Seal	Temperature Range °C
				Min	Max		AC Holding	DC Watt			
					AC	DC					
A106CV30//.....	3/8"	3	0.25	0	15	10	12 VA	8 W	A6	FPM=V	-10 +130
A106CV35//.....	3/8"	3.5	0.32	0	10	8					
A106CV40//.....	3/8"	4	0.36	0	8	5					
A106CV45//.....	3/8"	4.5	0.41	0	6.5	3.5					
A106CV52//.....	3/8"	5.2	0.47	0	4	1.8					
A106CV64//.....	3/8"	6.4	0.64	0	3	1					
A106DV30//.....	1/2"	3	0.25	0	15	10					
A106DV35//.....	1/2"	3.5	0.32	0	10	8					
A106DV40//.....	1/2"	4	0.36	0	8	5					
A106DV45//.....	1/2"	4.5	0.41	0	6.5	3.5					
A106DV52//.....	1/2"	5.2	0.47	0	4	1.8					
A106DV64//.....	1/2"	6.4	0.64	0	3	1					

② Coil



COILS	Alternating Current ~50/60Hz Volt				Direct Current Volt			Electrical connection
	24	48	110	220 230	12	24	48	
Series A6 Code ②	A6B	A6C	A6D	A6E	A60	A61	A62	1/2" NPT

DESCRIPTION
Voltage tolerance
AC +15% -10%
DC ±10%
Protection class IP66

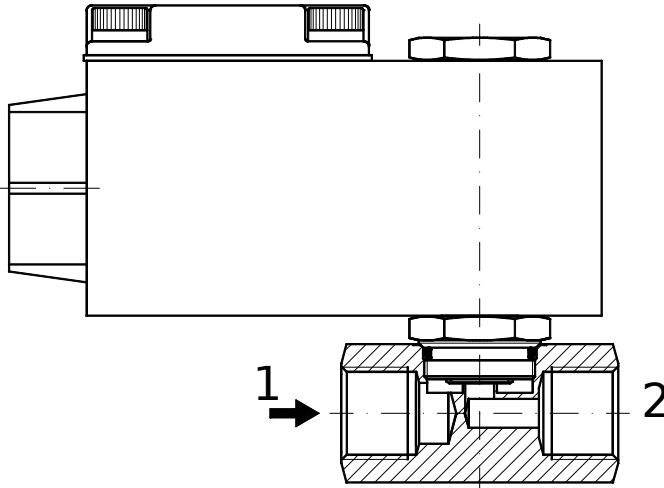

OVERALL DIMENSION

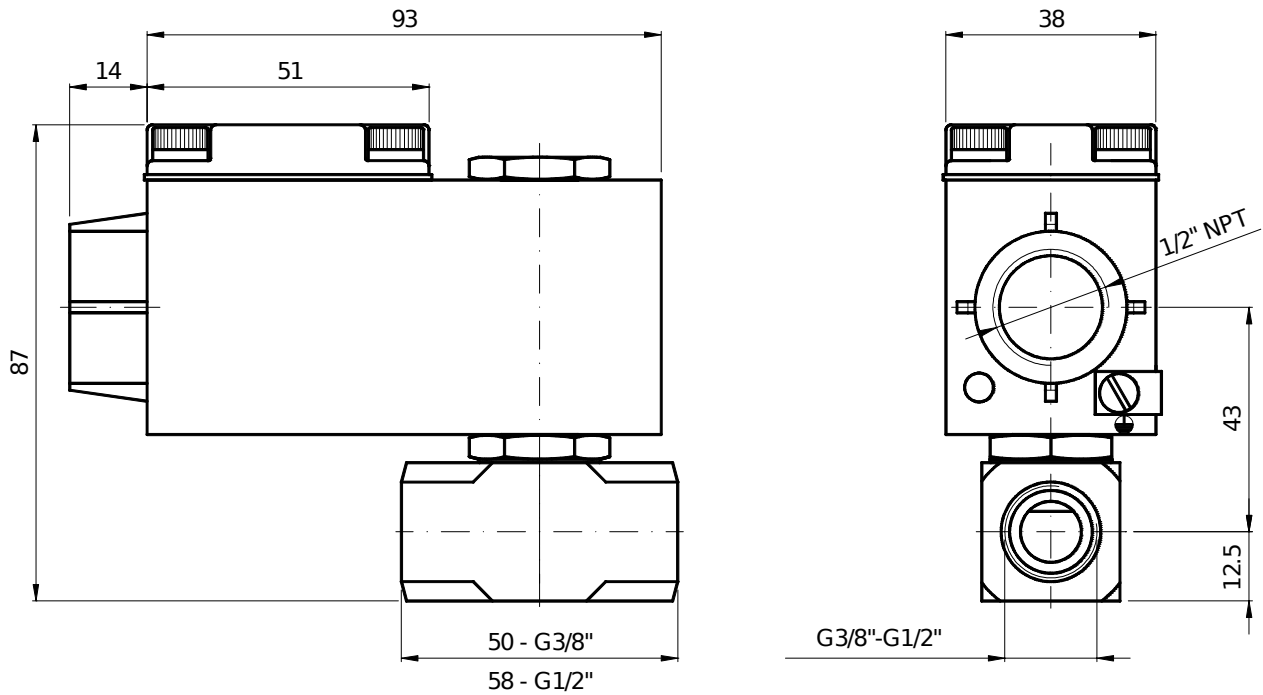

Weight = 0.66 Kg