

DESCRIPTION

Solenoid valve 3 way normally closed
direct acting poppet type for modular construction

CONSTRUCTION

Body	Die-cast aluminium
Armature tube	Brass
Plunger and core	Stainless steel
Springs	Stainless steel
Seal material	NBR
	FPM
	EPDM



FEATURES

Media : Air, Neutral gases
Ambient temperature : with class F coil -10°C +55°C
with class H coil -10°C +80°C
Universal mounting position

OPTIONS : Manual override
Stainless steel armature tube
Electroless nickel plating
Explosion proof coil according to ATEX - EExmII Series 7
Wet proof coil fixing nut

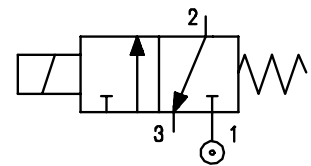

3

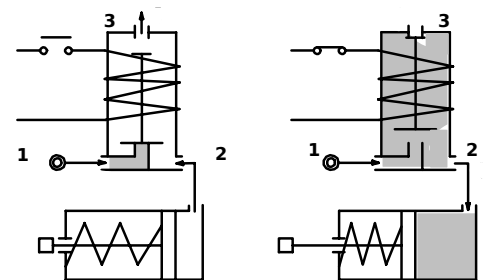

NOTE: This valve ISN'T standard. Contact the manufacturer for any question

CODE ① ②	Connection	Orifice mm		KV m³/h	Differential pressure bar			Nominal power			Coil		Seal ①	Temp. range °C
		Inlet	Exh.		Min	Max		AC Inrush	VA Holding	DC Watt	Series	Width		
						AC	DC							
E350B.....15///.....	G1/4"	1.5	1.5	0.06	0	10	10	12	8	6.5	3	22	NBR=B	-10 +90
E350B.....17///.....	G1/4"	1.7	1.7	0.08	0	8	8	12	8	6.5	3	22		
E350B.....17///.....	G1/4"	1.7	1.7	0.08	0	10	10	15	11	5	4	30	EPDM=E	<+140
E350M.....15///.....	M12x1.5	1.5	1.5	0.06	0	10	10	12	8	6.5	3	22		
E350M.....17///.....	M12x1.5	1.7	1.7	0.08	0	8	8	12	8	6.5	3	22	FPM=V	-10 +130
E350M.....17///.....	M12x1.5	1.7	1.7	0.08	0	10	10	15	11	5	4	30		

- ① Seal
- ② Coil

Example: E350MV17///30B FPM seal M12x1.5 connection
Coil 24V 50/60Hz

COILS	Alternating Current ~50/60Hz Volt							Direct Current Volt			Electrical connection	Connectors
	12	24	48	110	220 230	240	380	12	24	48		
Series 3 Width 22 Code ②	30A	30B	30C	30D	30E	30F	30G	300	301	302	DIN 46244	PG9 code 10348000
Series 4 Width 30 Code ②	40A	40B	40C	40D	40E	40F	40G	400	401	402	DIN 43650A	PG9 code 10349000

DESCRIPTION
 Class F insulation
 Voltage tolerance
 AC +15% -10%
 DC ±10%
 Protection class
 IP65 with connector fitted
 IP00 without connector
 Continuous service ED100%

OPTIONS
 Class H insulation
 Cable attached
 Special coil voltage
 Special coil powers

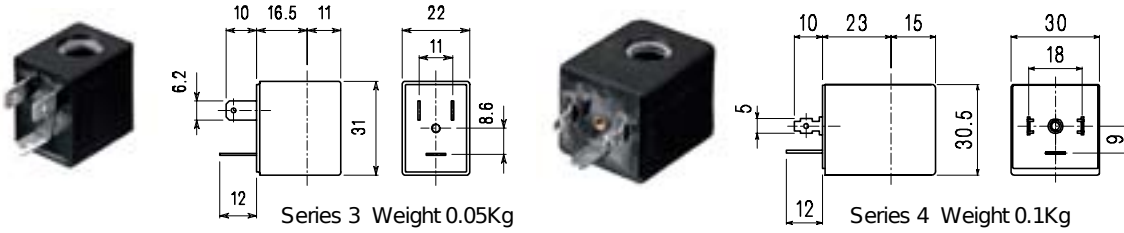

SPARE PARTS LIST

1. Coil fixing nut
2. Coil
3. Plunger
4. Armature tube with core

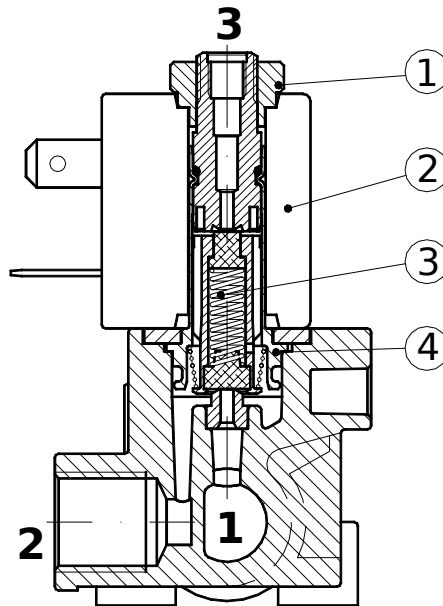

MANUAL OVERRIDE

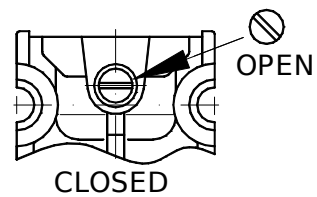

OVERALL DIMENSION

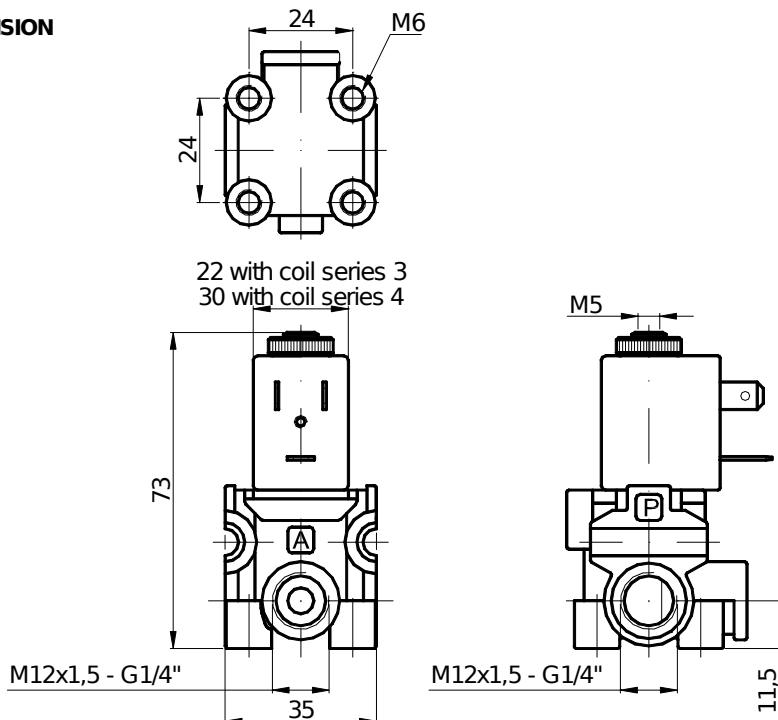

Weight with coil series 3 = 0.14 Kg
 Weight with coil series 4 = 0.19 Kg