

DESCRIPTION

Solenoid valve 2 way normally closed
direct acting poppet type

CONSTRUCTION

Body	Brass
Armature tube	Stainless steel
Plunger and core	Stainless steel
Springs	Stainless steel
Seal material	NBR
	FPM
	EPDM



2

FEATURES

Maximum allowable pressure 5 bar
 Maximum fluid viscosity 25cSt (mm²/s)
 Ambient temperature : with class F coil -10°C +55°C
 with class H coil -10°C +80°C
 Universal mounting position

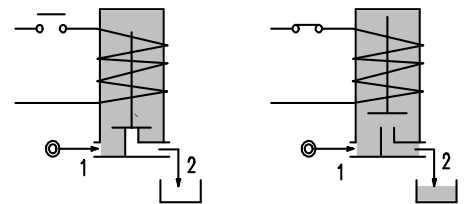
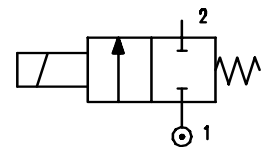

OPTIONS : Electroless nickel plating
 Version for use with oxygen

CODE ① ②	Connection G ISO 228	Orifice mm	KV m ³ /h	Differential pressure bar			Nominal power			Coil		Seal ①	Temp. range °C
				Min	Max		AC Inrush	VA Holding	DC Watt	Series	Width		
					AC	DC							
E109C.....12///.....	3/8"	12	2	0	0.5	0.06	20	15	10	2	30	NBR=B	-10 +90
E109D.....12///.....	1/2"	12	2.2	0	0.5	0.06	20	15	10	2	30		
E109E.....18///.....	3/4"	18	4.5	0	0.14	--	20	15	--	2	30	EPDM=E	<-140
E109C.....12///.....	3/8"	12	2	0	0.8	0.4	40	30	27	5	36		
E109D.....12///.....	1/2"	12	2.2	0	0.8	0.4	40	30	27	5	36	FPM=V	-10 +130
E109E.....18///.....	3/4"	18	4.5	0	0.2	0.12	40	30	27	5	36		

- ① Seal
- ② Coil

Example: E109EV18///52B FPM seal
 Coil 24V 50/60Hz

COILS	Alternating Current ~50/60Hz Volt							Direct Current Volt			Electrical connection	Connectors
	12	24	48	110	220 230	240	380	12	24	48		
Series 2 Width 30 Code ②	20A	20B	20C	20D	20E	20F	20G	200	201	202	DIN 43650A	PG9 code 10349000
Series 5 Width 36 Code ②	52A	52B	52C	52D	52E	52F	52G	521	521	522	DIN 43650A	PG11 code 10349001

DESCRIPTION
 Insulation class
 Series 2=F Series 5=H
 Voltage tolerance
 AC +15% -10%
 DC ± 10%
 Protection class
 IP65 with connector fitted
 IP00 without connector
 Continuous service ED100%

OPTIONS
 Class H insulation (series 2)
 Cable attached
 Special coil voltages
 Special coil powers

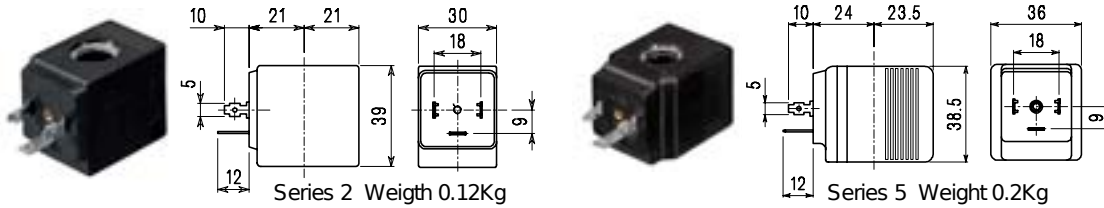

SPARE PARTS LIST

1. Coil fixing nut
2. Coil
3. Plunger
4. Armature tube with core
5. Body O-Ring

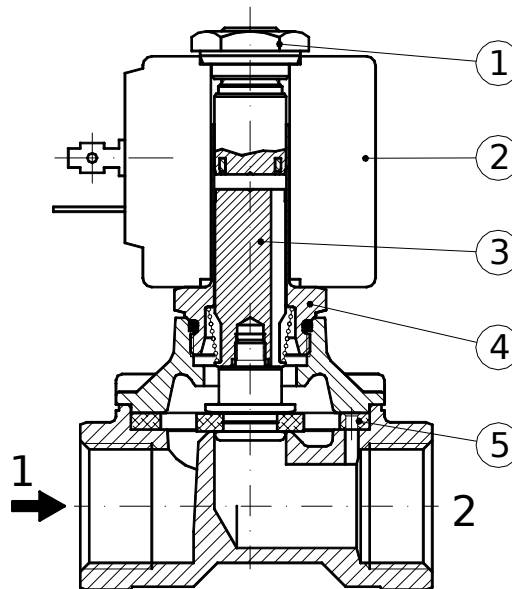

OVERALL DIMENSION

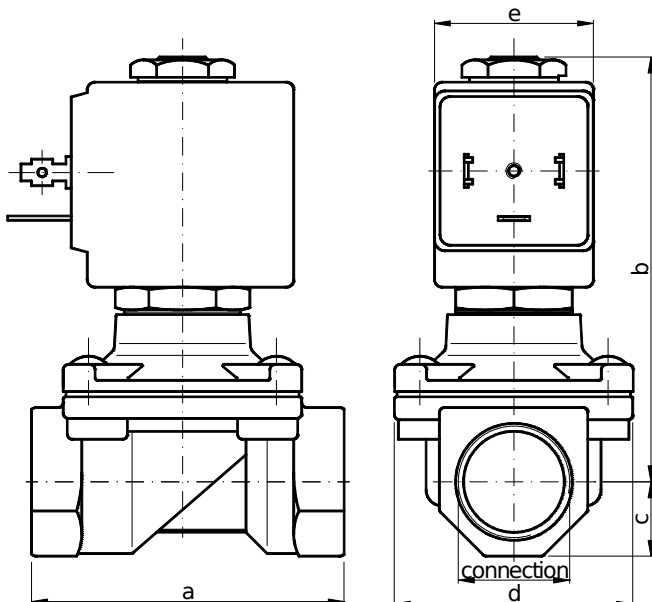

Connection	a	b	c	d	e		Weight kg	
					with series 2	with series 5	series 2	series 5
G3/8"	60	83	14	45	30	36	0.50	0.58
G1/2"	60	83	14	45	30	36	0.45	0.53
G3/4"	75	90	18	55	30	36	0.75	0.83