

DESCRIPTION

Solenoid valve 2 way normally closed
direct acting poppet type

CONSTRUCTION

Body	Brass
Armature tube	Brass
Plunger and core	Stainless steel
Springs	Stainless steel
Seal material	NBR
	FPM
	EPDM



2

FEATURES

Maximum allowable pressure 50 bar *
 Maximum fluid viscosity 25cSt (mm²/s)
 Ambient temperature : with class F coil -10°C +55°C
 with class H coil -10°C +80°C
 Universal mounting position

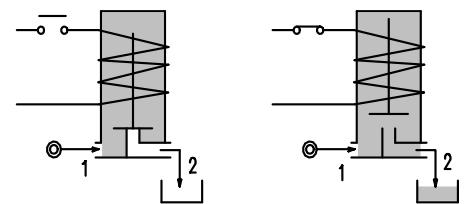
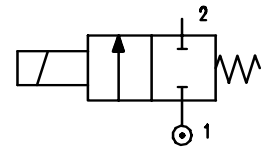

- OPTIONS :** Armature tube in stainless steel
 Electroless nickel plating
 Explosion proof coil according to ATEX - EExmI Series7
 Manual override
 Version for use with oxygen

CODE ① ②	Connection G ISO 228	Orifice mm	KV m ³ /h	Differential pressure bar			Nominal power			Coil		Seal ①	Temp. range °C
				Min	Max		AC Inrush	VA Holding	DC Watt	Series	Width		
					AC	DC							
E105A.....12///.....	1/8"	1.2	0.04	0	25	25	12	8	6.5	3	22	NBR=B	-10 +90
E105A.....15///.....	1/8"	1.5	0.06	0	16	16	12	8	6.5	3	22		
E105A.....20///.....	1/8"	2	0.09	0	12	10	12	8	6.5	3	22		
E105A.....25///.....	1/8"	2.5	0.14	0	8	5.5	12	8	6.5	3	22		
E105A.....31///.....	1/8"	3.1	0.19	0	5	2	12	8	6.5	3	22		
E105A.....40///.....	1/8"	4	0.35	0	4	1.5	12	8	6.5	3	22		
E105A.....20///.....	1/8"	2	0.09	0	25	15	15	11	5	4	30	EPDM=E	<+140
E105A.....25///.....	1/8"	2.5	0.14	0	16	8	15	11	5	4	30		
E105A.....31///.....	1/8"	3.1	0.19	0	8	4	15	11	5	4	30		
E105A.....40///.....	1/8"	4	0.35	0	5	2.5	15	11	5	4	30		

- ① Seal
- ② Coil

Example: E105AB20///30B NBR seal
 Coil 24V 50/60Hz

* REMARK: The maximum allowable pressure PS for steam is 2,5bar (gauge pressure)

COILS	Alternating Current ~50/60Hz Volt							Direct Current Volt			Electrical connection	Connectors
	12	24	48	110	220 230	240	380	12	24	48		
Series 3 Width 22 Code ②	30A	30B	30C	30D	30E	30F	30G	300	301	302	DIN 46244	PG9 code 10348000
Series 4 Width 30 Code ②	40A	40B	40C	40D	40E	40F	40G	400	401	402	DIN 43650A	PG9 code 10349000

DESCRIPTION
 Class F insulation
 Voltage tolerance
 AC +15% -10%
 DC ±10%
 Protection class
 IP65 with connector fitted
 IP00 without connector
 Continuous service ED100%

OPTIONS
 Class H insulation
 Cable attached
 Special coil voltage
 Special coil powers

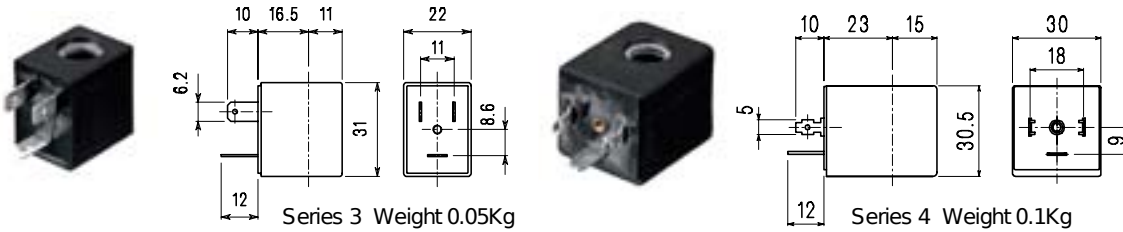

SPARE PARTS LIST

1. Coil fixing nut
2. Coil
3. Plunger
4. Armature tube with core

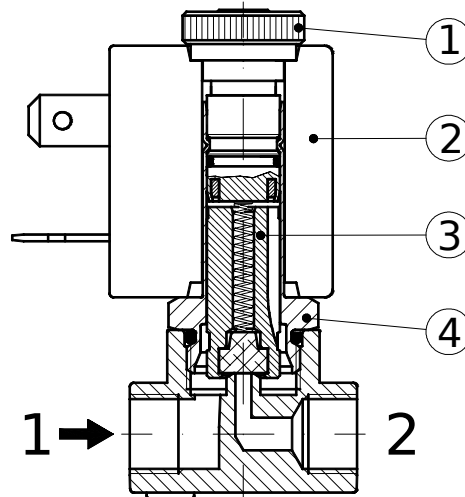

MANUAL OVERRIDE

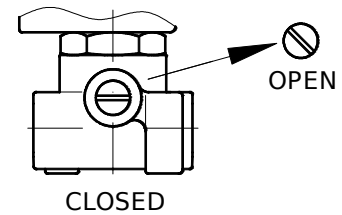

OVERALL DIMENSION

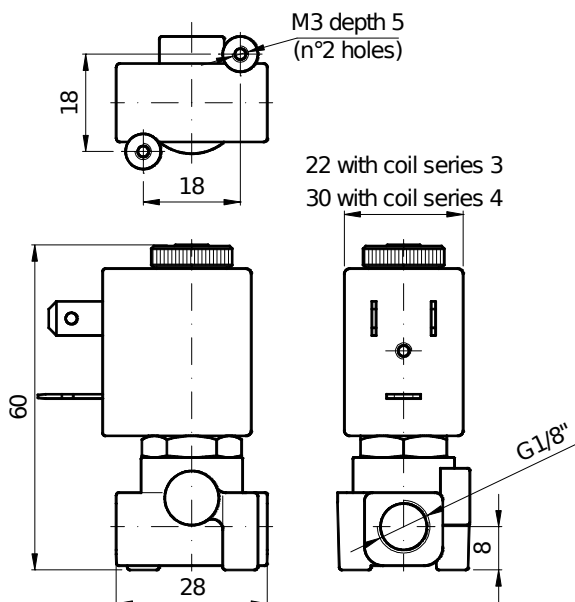

Weight with coil series 3 = 0.13 Kg
 Weight with coil series 4 = 0.18 Kg